

## Product Summary

$V_{DS}$ (V)	$R_{DS(on),max}$ (mΩ)	$I_D$ (A)
200	16 @ $V_{GS} = 10V$	81 <sup>(1)</sup>

## Features

- Low  $R_{DS(on)}$  SGT technology
- Low thermal impedance
- Fast switching speed
- 100% avalanche tested

## Application

- DC/DC conversion
- Power switch
- Synchronous Rectification in SMPS

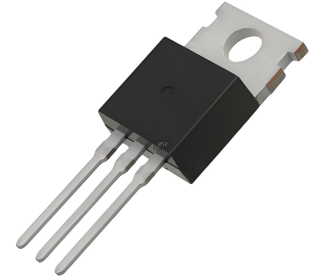

## Equivalent circuit

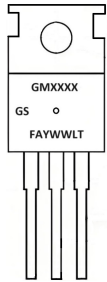
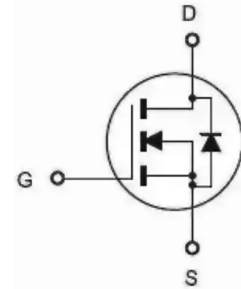

**TO-220**

NOTE:  
 LOGO - GS  
 GMXXXX- Part number code  
 F - Fab location code  
 A - Assembly location code  
 Y - Year code  
 WW - Week code  
 L&T - Assembly lot code

## Absolute maximum rating@25°C

Parameter	Symbol	Limit	Unit
Drain-source voltage	$V_{DS}$	200	V
Gate-source voltage	$V_{GS}$	±20	
Continuous drain current	$I_D$	$T_C=25^\circ C$ <sup>(1)</sup>	81
		$T_C=100^\circ C$	58
Pulsed drain current <sup>(2)</sup>	$I_{D,pulse}$	326	A
Avalanche energy, single pulse <sup>(3)</sup>	$E_{AS}$	922	mJ
Power dissipation	$P_D$	$T_C=25^\circ C$	288
		$T_A=25^\circ C$ <sup>(4)</sup>	144
Operating junction and storage temperature range	$T_J, T_{stg}$	-55 to 150	°C

## Thermal Characteristic

Parameter	Symbol	Max.	Unit
Thermal resistance, junction-to-case	$R_{\theta JC}$	0.52	°C/W
Thermal resistance, junction-to-ambient <sup>(4)</sup>	$R_{\theta JA}$	33	

**Electrical Characteristics (T<sub>J</sub>=25°C unless otherwise noted)**

Parameter	Symbol	Test conditions	Min.	Typ.	Max.	Unit
<b>Static parameter</b>						
Drain to source breakdown voltage	V <sub>(BR)DSS</sub>	V <sub>GS</sub> = 0, I <sub>D</sub> = 250 μA	200			V
Gate-source threshold voltage	V <sub>GS(th)</sub>	V <sub>DS</sub> = V <sub>GS</sub> , I <sub>D</sub> = 250 μA	2.5	3.4	4.5	V
Gate-body leakage	I <sub>GSS</sub>	V <sub>DS</sub> = 0 V, V <sub>GS</sub> = ±20 V			±100	nA
Zero gate voltage drain current	I <sub>DSS</sub>	V <sub>DS</sub> = 100 V, V <sub>GS</sub> = 0 V			1	μA
Drain-source on-resistance	R <sub>DS(on)</sub>	V <sub>GS</sub> = 10 V, I <sub>D</sub> = 50 A		13.6	16	mΩ
Forward transconductance <sup>(5)</sup>	g <sub>fs</sub>	V <sub>DS</sub> = 5 V, I <sub>D</sub> = 50 A		38		S
Gate resistance	R <sub>g</sub>	f = 1 MHz		2.5		Ω
<b>Dynamic <sup>(5)</sup></b>						
Total gate charge V <sub>GS</sub> = 10 V	Q <sub>g</sub>	V <sub>DS</sub> = 100 V, I <sub>D</sub> = 20 A, V <sub>GS</sub> = 10 V		31		nC
Gate-source charge	Q <sub>gs</sub>			9.8		
Gate-drain charge	Q <sub>gd</sub>			7.7		
Turn-on delay time	t <sub>d(on)</sub>	V <sub>DS</sub> = 100 V, I <sub>D</sub> = 20 A, V <sub>GS</sub> = 10 V, R <sub>GEN</sub> = 3 Ω		14		ns
Rise time	t <sub>r</sub>			16		
Turn-off delay time	t <sub>d(off)</sub>			28		
Fall time	t <sub>f</sub>			12		
Input capacitance	C <sub>iss</sub>	V <sub>DS</sub> = 100 V, V <sub>GS</sub> = 0 V, f = 1 MHz		2050		pF
Output capacitance	C <sub>oss</sub>			297		
Reverse transfer capacitance	C <sub>rss</sub>			11		
<b>Reverse Diode Characteristics <sup>(5)</sup></b>						
Diode forward voltage	V <sub>SD</sub>	V <sub>GS</sub> = 0 V, I <sub>F</sub> = 2 A		0.7	1.2	V
Reverse recovery time	t <sub>rr</sub>	I <sub>F</sub> = 20 A, di/dt = 100 A/μs		120		ns
Reverse recovery charge	Q <sub>rr</sub>				524	

## Notes

- (1) Package limited.
- (2) Pulse width limited by maximum junction temperature.
- (3) V<sub>DS</sub> = 100 V, V<sub>GS</sub> = 10 V, L = 1.0 mH.
- (4) Device mounted on FR-4 substrate PC board with 2oz copper in 1inch square cooling area.
- (5) Guaranteed by design, not subject to production testing.



### Typical Performance Characteristics

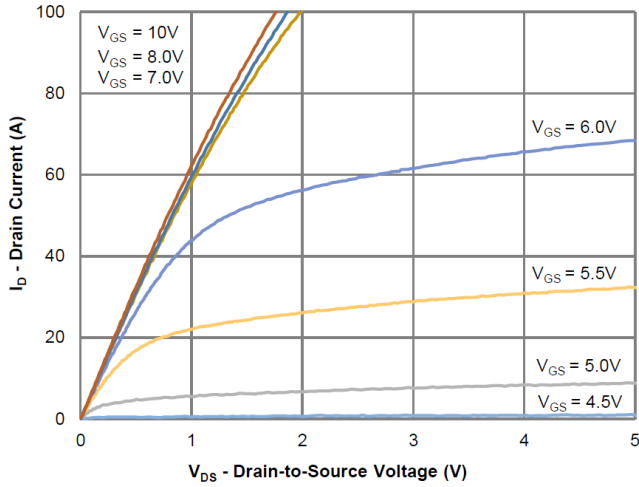

Figure 1: Output Characteristics

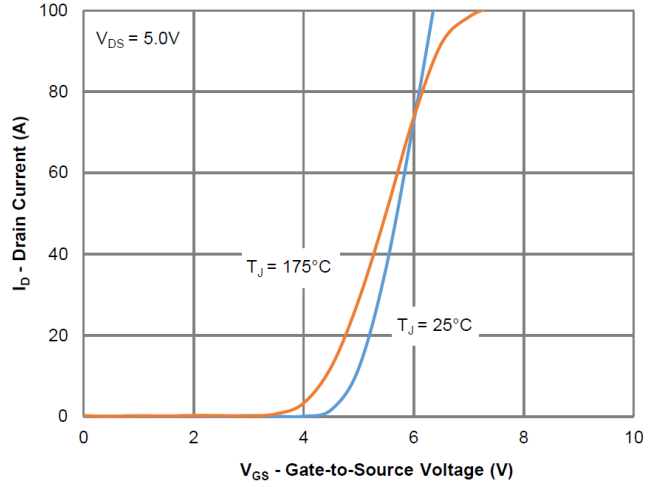

Figure 2: Transfer Characteristics

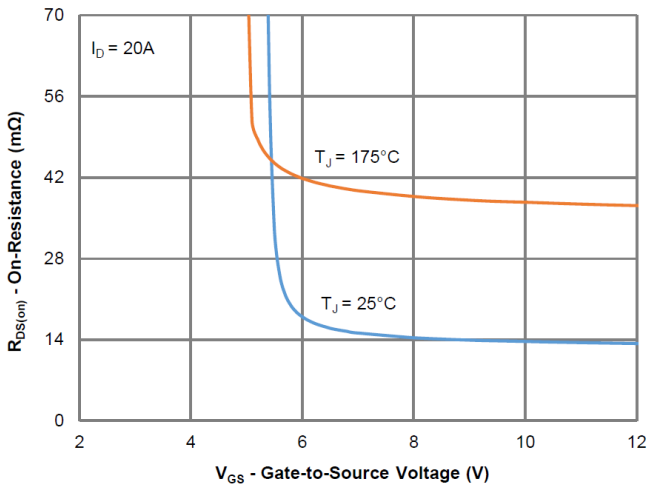

Figure 3: On-Resistance vs. Gate-Source Voltage

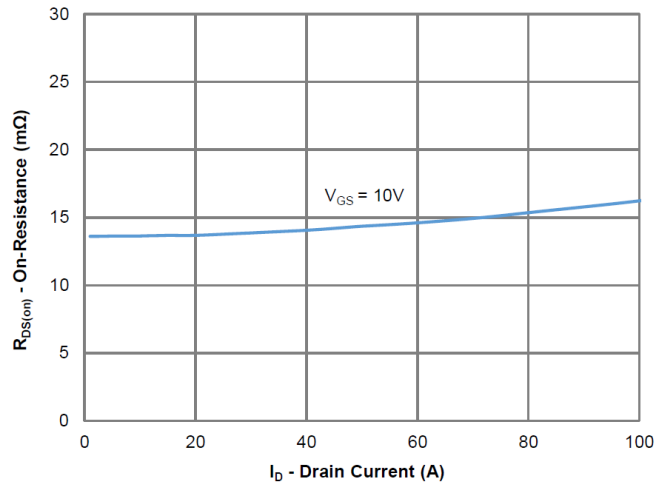

Figure 4: On-Resistance vs. Gate-Source Voltage

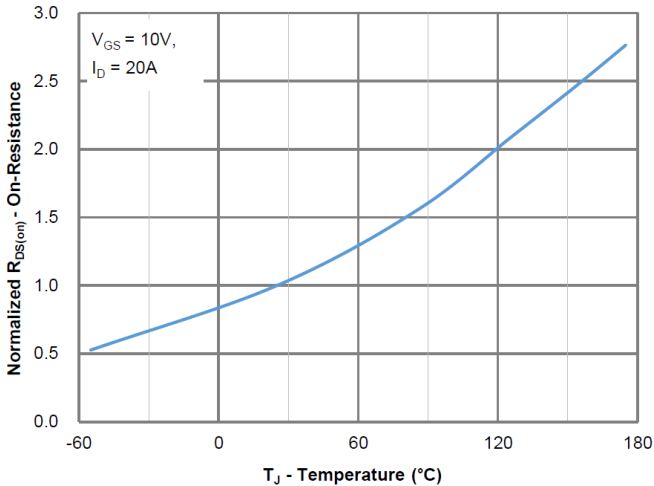

Figure 5: On-Resistance vs. Junction Temperature

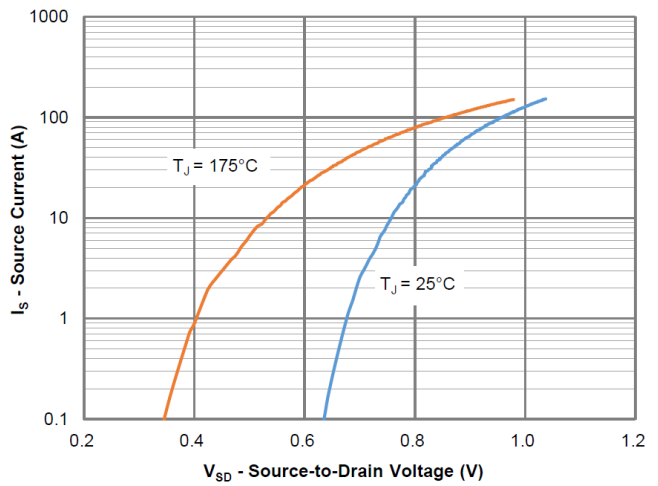

Figure 6: Source-Drain Diode Forward Voltage



### Typical Performance Characteristics

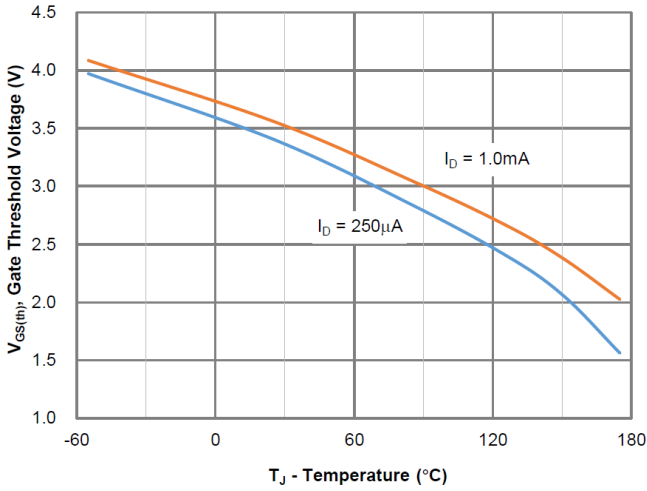

Figure 7: Gate Threshold Variation vs. Junction Temperature

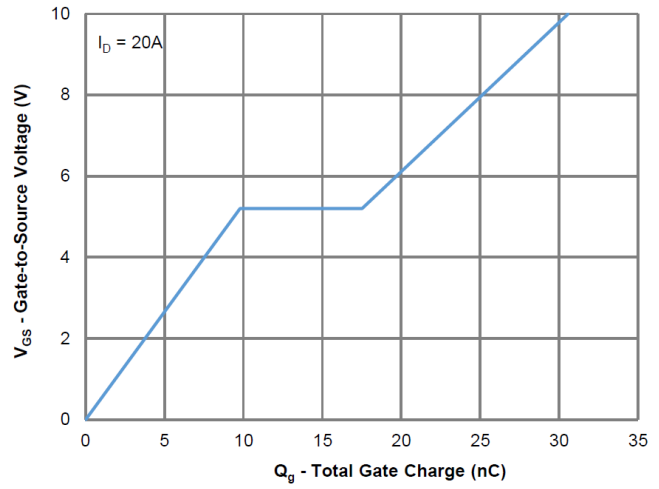

Figure 8: Gate Charge Characteristics

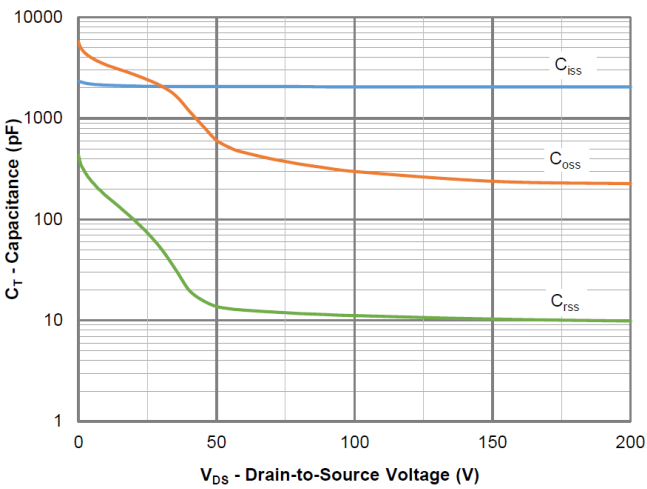

Figure 9: Capacitance Characteristics

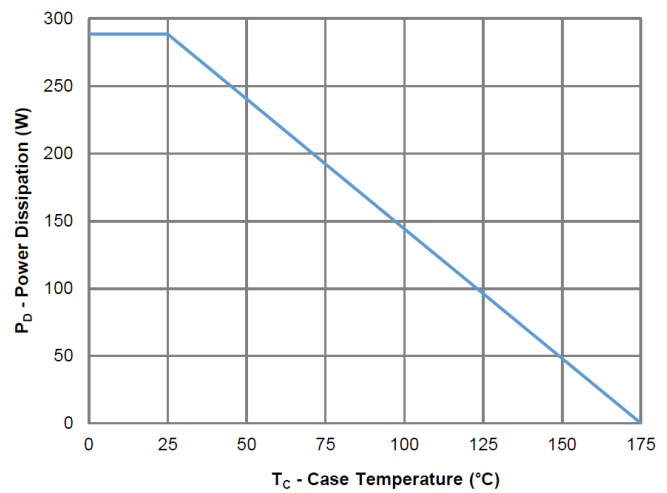

Figure 10: Power Derating

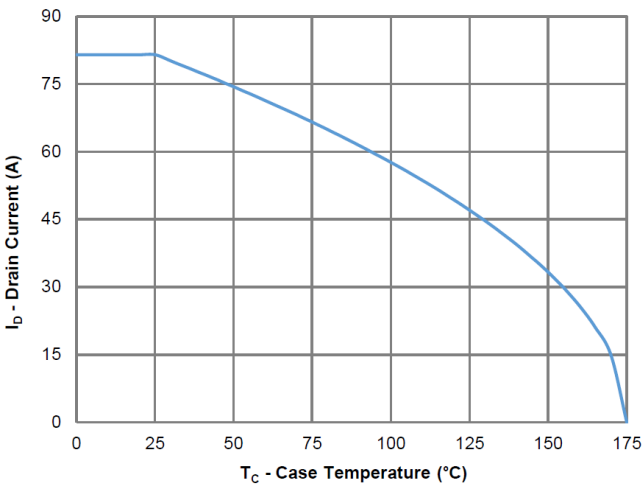

Figure 11: Current Derating

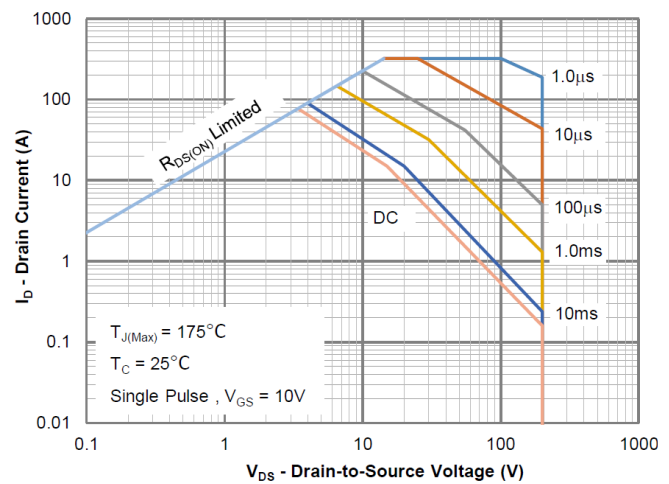

Figure 12: Safe Operating Area



Typical Performance Characteristics

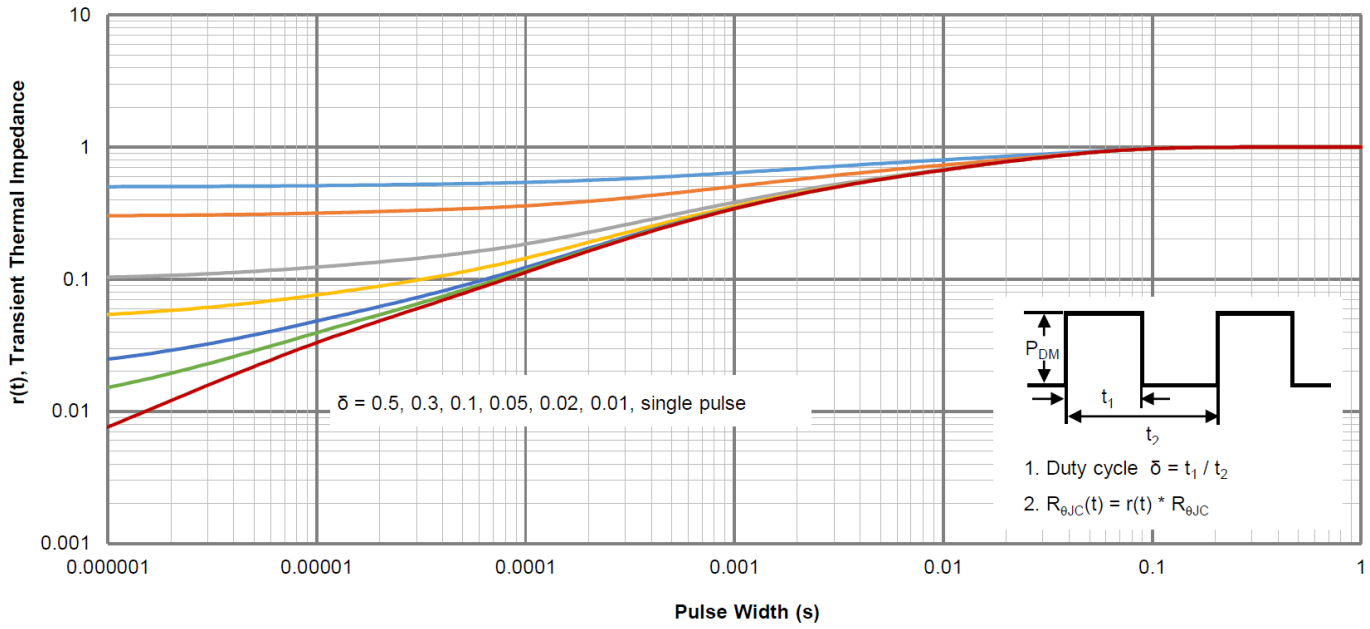
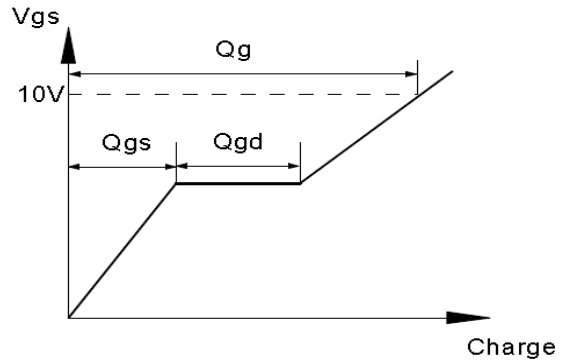
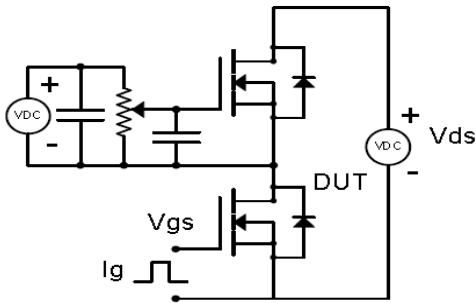

Figure 13: Normalized Maximum Transient Thermal Impedance



Test Circuit & Waveform

Gate Charge Test Circuit & Waveform



Resistive Switching Test Circuit & Waveforms

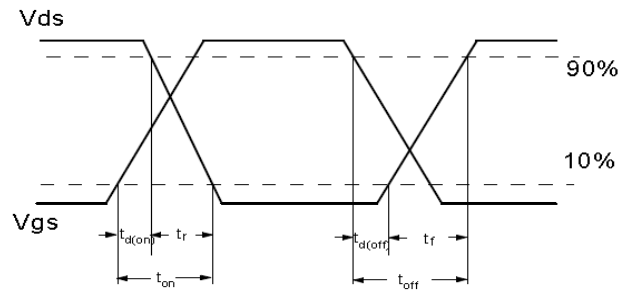
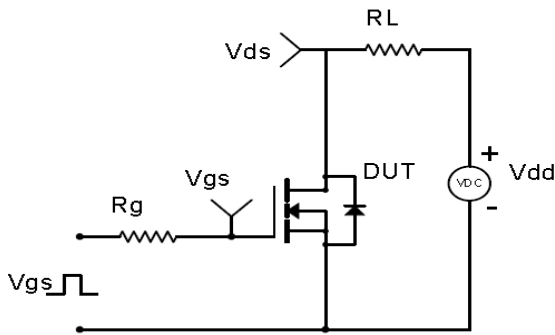

Unclamped Inductive Switching (UIS) Test Circuit & Waveforms

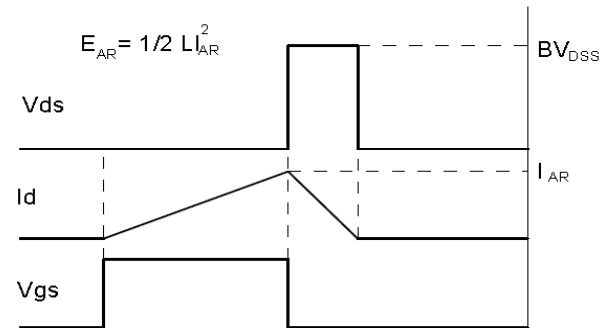
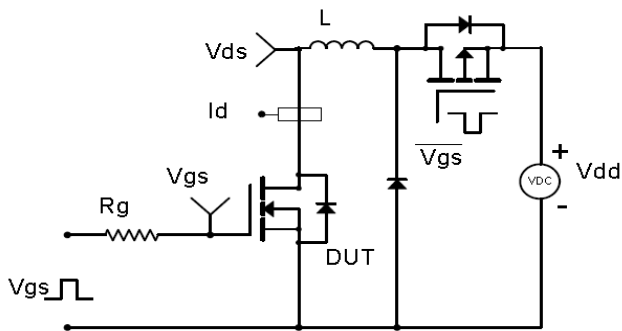

Diode Recovery Test Circuit & Waveforms

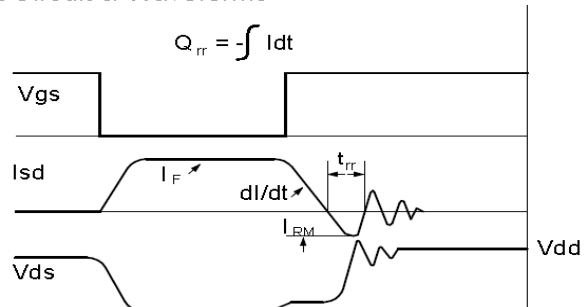
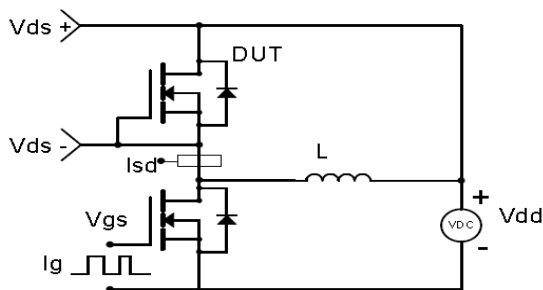



Outline Drawing TO-220

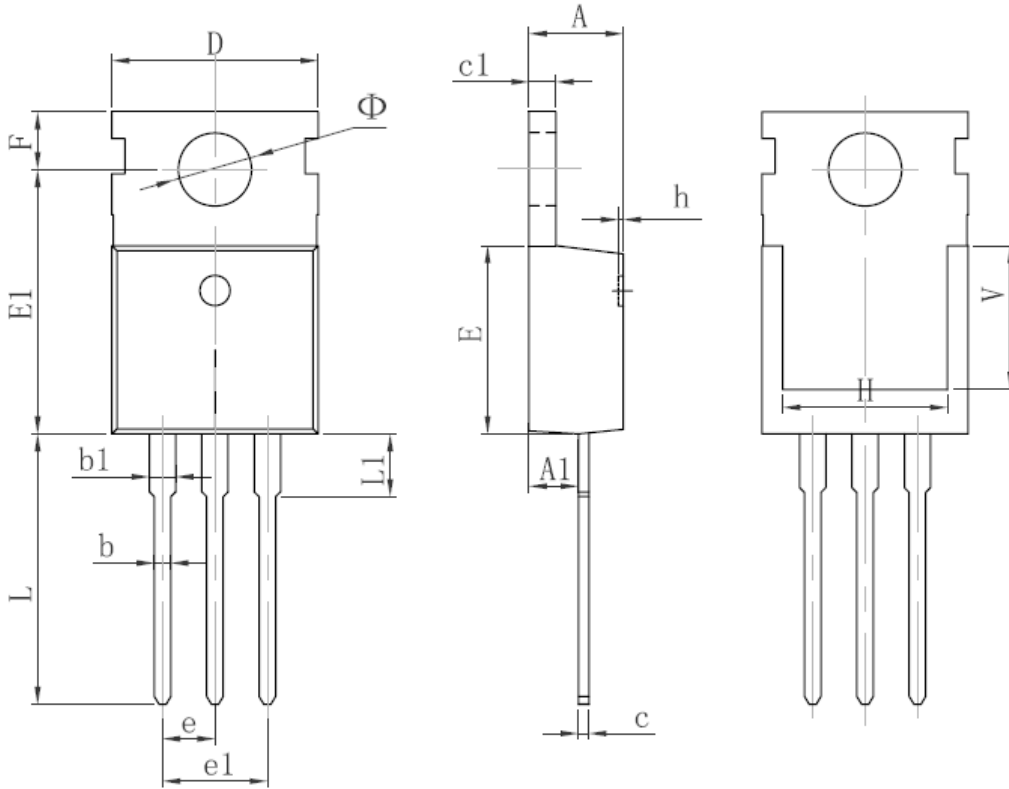

Symbol	Dimensions In Millimeters		
	Min.	NOM.	Max.
A	4.40	-	4.60
A1	2.25	-	2.55
b	0.71	-	0.91
b1	1.17	-	1.37
c	0.33	-	0.65
c1	1.20	-	1.40
D	9.91	-	10.25
E	8.95	-	9.75
E1	12.65	-	13.05
e	2.54 TYP-		
e1	4.98	-	5.18
F	2.65	-	2.95
H	7.90	-	8.10
h	0.00	-	0.30
L	12.90	-	13.40
L1	2.85	-	3.25
V	6.90 REF		
phi	3.40	-	3.80

## Important Notice

The information given in this document shall be for illustrative purposes only and shall in no event be regarded as a guarantee of conditions or characteristics. Gostone reserves the right to change any information herein. With respect to any examples, hints or any typical values stated herein and/or any information regarding the application of the product, Gostone or its affiliates hereby make no representation or warranty of any kind, expressed or implied, as to any information provided hereunder, including without limitation as to the accuracy, completeness or non-infringement of intellectual property rights of any third party, and they assume no liability for the consequences of use of such information. In addition, any information given in this document is subject to customer's compliance with its obligations stated herein and any applicable legal requirements, norms and standards concerning customer's products and any use of the product of Gostone in customer's applications. The information contained herein is exclusively intended for technically trained staff. No license is granted by implication under any patent right, copyright, mask work right, or other intellectual property right. It is customer's sole responsibility to evaluate the suitability of the product for the intended application and the completeness of the product information given herein with respect to such application. In no event shall Gostone or its affiliates be liable to any party for any direct, indirect, special, punitive, incidental or consequential damages of any nature whatsoever, including but not limited to loss of profits and loss of goodwill, whether or not such damages are based on tort or negligence, warranty, breach of contract or any other legal theory. In addition, any recipient of this document and the relevant products samples may not alter, decompile, disassemble, reverse engineer, or otherwise modify any information/samples received hereunder. Any intellectual property rights arising from the reverse engineering of Gostone's products shall belong to Gostone.